

AVA01/GABU

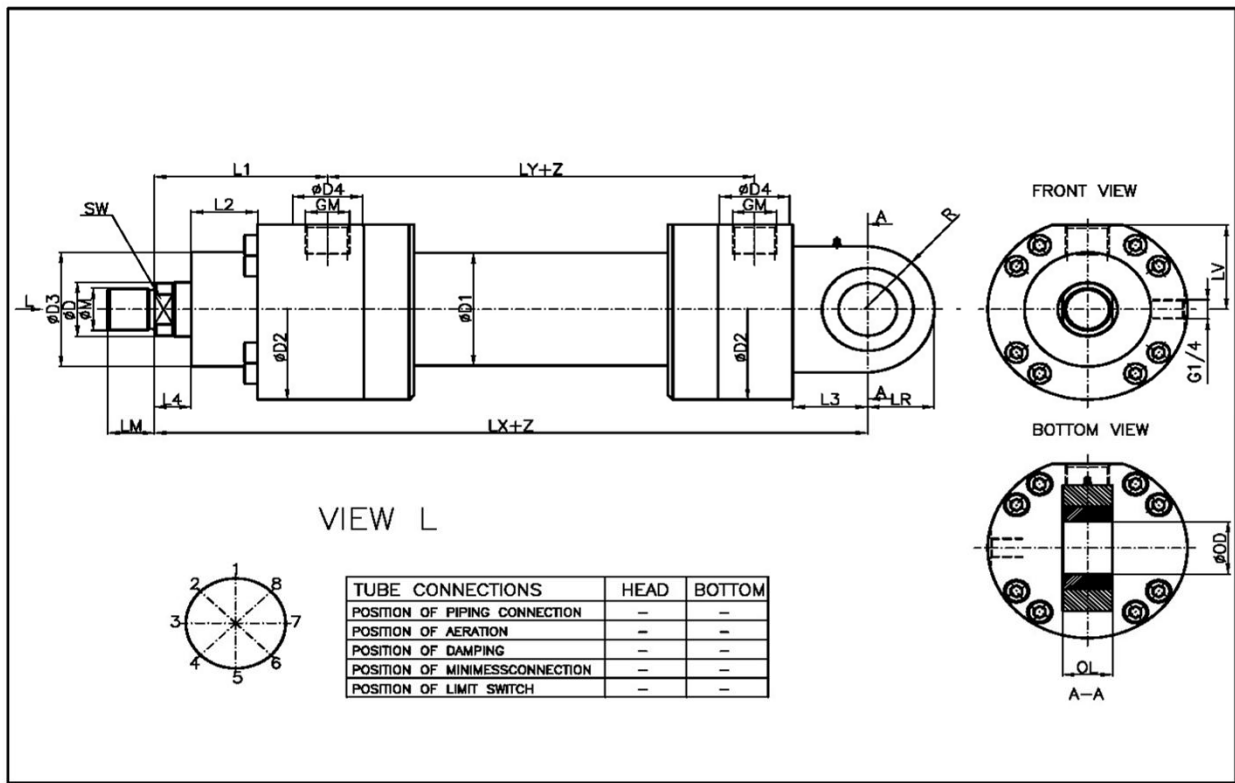

ØD	Ød	LX	LY	M	LM	SW	ØD1	ØD2	ØD3 f8	ØD4 max. 0.5mm deep	GM	GM	L1	L2
40	22/28	252	120	M16x1.5	16	17/22	40	88	51	34	G1/2	M22x1.5	70	35
50	28/36	265	120	M22x1.5	22	22/30	65	102	64	34	G1/2	M22x1.5	99	35
63	36/45	302	133	M28x1.5	28	30/36	75	120	76	42	G3/4	M27x2	104	40
80	45/56	330	146	M35x1.5	35	36/46	95	140	92	42	G3/4	M27x2	121	40
100	56/70	385	171	M45x1.5	45	46/60	115	170	119	47	G1	M33x2	125	50
125	70/90	447	205	M58x1.5	58	60/75	145	206	134	58	G1 1/4	M45x2	154	55
140	90/100	490	219	M65x1.5	65	75/85	170	226	156	58	G1 1/4	M42x2	157	55
160	100/110	550	240	M80x2	80	85/95	185	265	180	65	G1 1/2	M48x2	204	65
180	110/125	610	264	M100x2	100	95/110	210	292	185	65	G1 1/2	M48x2	195	75
200	125/140	645	278	M110x2	110	110/120	235	310	228	65	G1 1/2	M48x2	195	80
ØD	Ød	L3	L4	R	LR	LV	ØDH 11	OL -0.4						
40	22/28	32.5	14	31	28	41	25	23						
50	28/36	37.5	18	36	32.5	48.5	30	28						
63	36/45	45	22	42	40	56.5	35	30						
80	45/56	50	20	52	50	67	40	35						
100	56/70	60	30	65	62.5	82	50	40						
125	70/90	70	32	52	70	99	60	50						
140	90/100	75	35	65	82	109.5	70	55						
160	100/110	85	40	70	95	129	80	60						
180	110/125	90	40	82	113	142.5	90	65						
200	125/140	115	40	95	125	152	100	70						

ØD=Piston Ø(mm)
 Ød=Piston rod Ø(mm)
 Z= Stroke length